

KUTTING-EDGE.

Pathway Edger for Cushman®Truckster

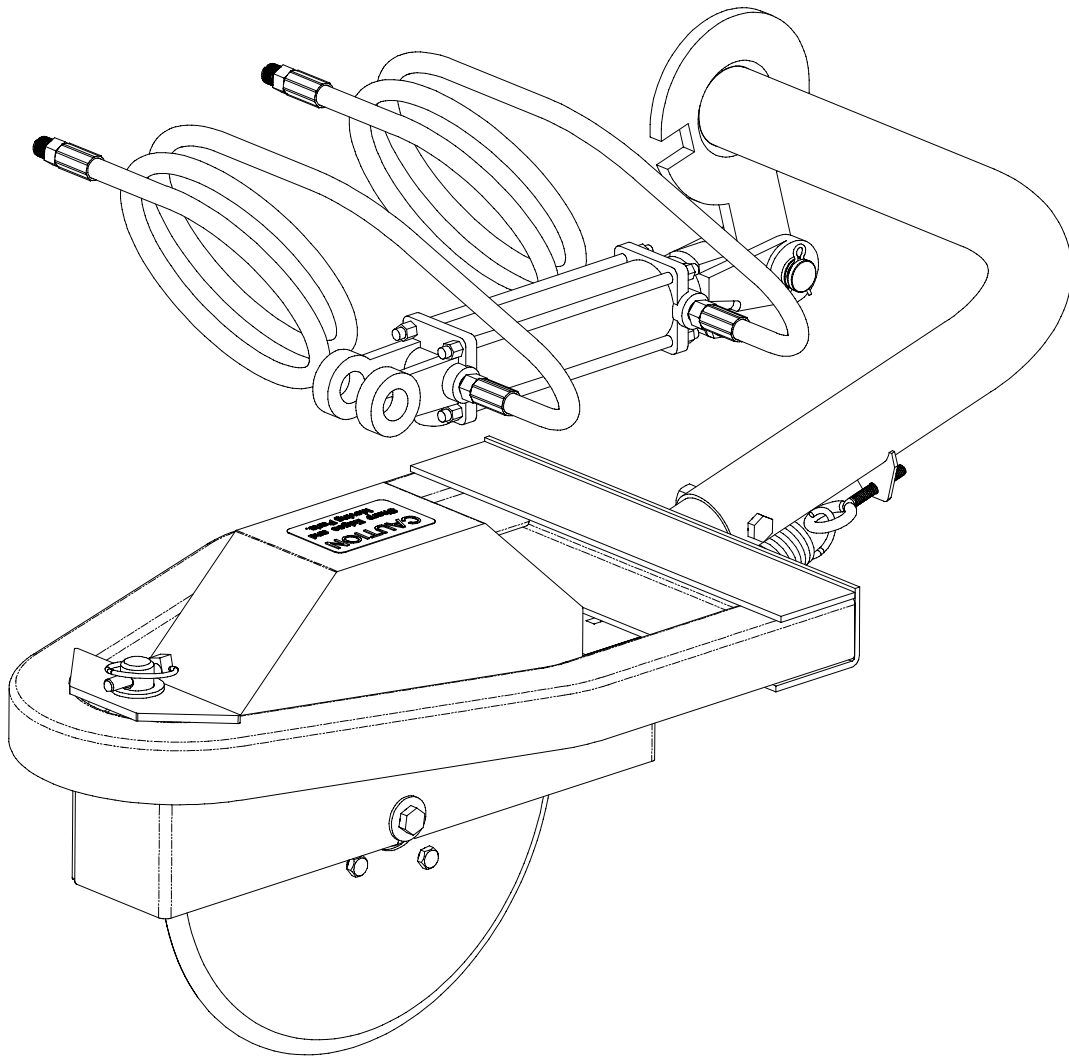

BISHOP ENTERPRISES, INC.

9033 Shelbyville Hwy. Bell Buckle, TN 37020

Tel: 615.793.6052 Fax: 615.793.9525



Look For Other Great BEI Products On The Web at
www.turf-aire.com

Hole	Mounting Purpose
A	Old Model Truckster
B & B1	New Truckster Without Mounting Kit
C	New Truckster With Mounting Kit

Hole Sizes	
A & C	5/8" Diameter
B	1/2" Diameter
B1	7/16" Diameter

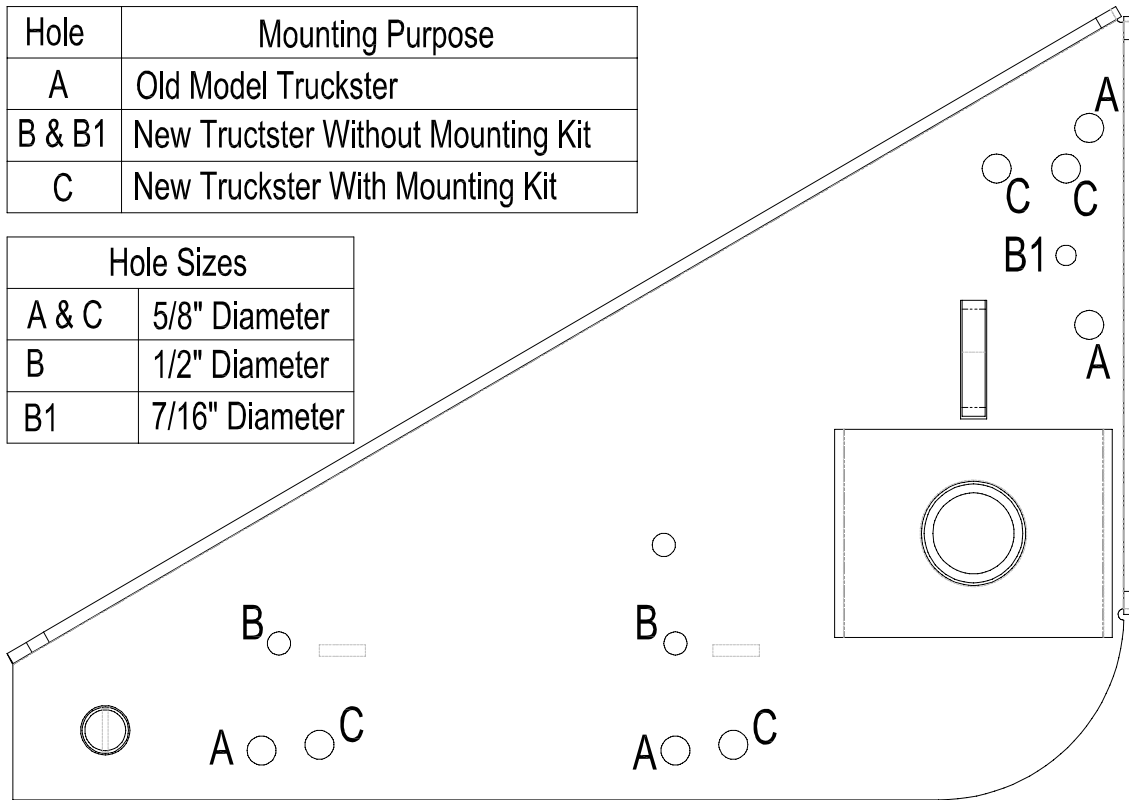

Mounting Plate Template

Use the illustration to the left to help locate the proper set of holes for your installation of the the BEI Cutting Edge Pathway Edger.

Two Choices For Mounting Your BEI Edger To A New Model Cushman Truckster

1.) New Model CUSHMAN® TRUCKSTER w/o mounting kit:

Three (3) holes must be drilled in the frame of a "new" style Cushman® Truckster when **not** using Mounting Kit. See Figure #1. With side plate clamped securely to the Truckster side frame, use a center punch to mark the location where holes are to be drilled in the Truckster side frame. The letter [B] on the mounting template included, indicates which set of holes to use for the Side Mounting Plate. Use a 5/8" drill bit for the [B] bottom holes and a 7/16" drill bit for [B] top hole.

Warning:Drilling holes into the frame of the Cushman Truckster may alter the manufacturers warranty.

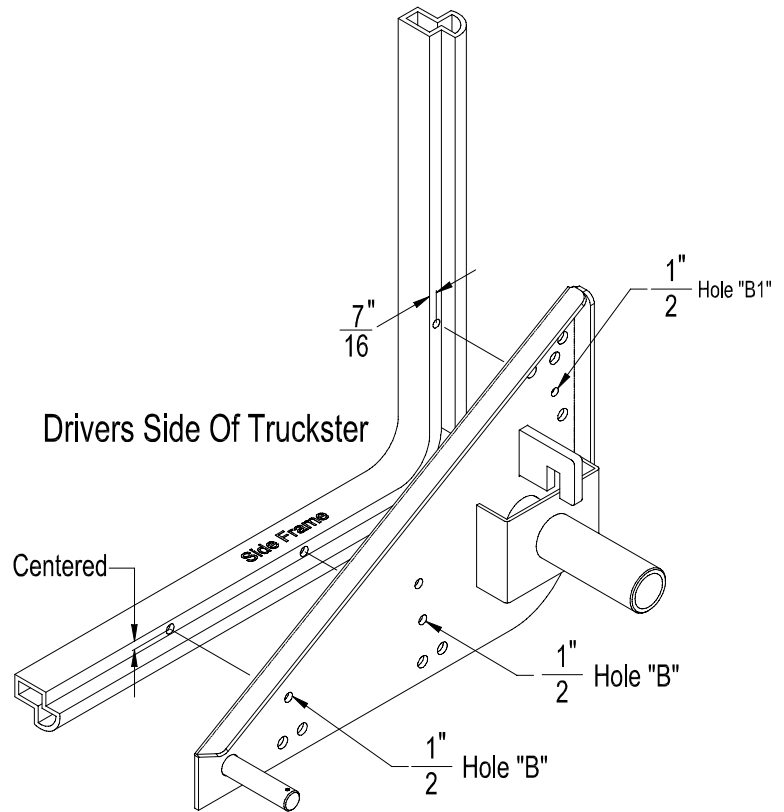

2.) New Model CUSHMAN® TRUCKSTER With Mounting Kit:

Remove bolt [D] designated in Figure #2*. This bolt is used as one of the fasteners for the Truckster's motor mount. (Note: Using the Mounting Kit requires no holes to be drilled in the Truckster side frame.)

After Bolt [D] is removed, slide the Bottom Bracket [6] onto the lip of the Truckster's driver side frame with holes [D] on the Truckster's frame. Using the included 7/16" x1" bolt, 7/16" lockwasher and 7/16" nut, fasten the bracket to the Truckster frame.

Now place the Mounting Plate [4] onto the outside lip of the Bottom Bracket [6]. Align welded bolts on Bottom Bracket with holes in Side Mounting Plate. Use the included 1/2" nuts and lockwashers to secure the Mounting Plate to the Bottom Bracket.

Slide the Top Bracket [3] onto the Truckster's side frame and line up with the appropriate holes. Use the included 1/2"x1"bolts, 1/2" nuts and 1/2" lockwashers to secure the Top Bracket.

***CAUTION: Bolt [D] secures the Motor Mounting Bracket**

Parts List For Mounting Bracket			
Item #	Qty.	Part #	Description
1	4	e10113	1/2" Nut
2	4	e10014	1/2" Lockwasher
3	1	e10108	Top Bracket
4	1	e10012C	Mounting Plate
5	2	e10112	1/2" Bolt
6	1	e10107	Bottom Bracket
7	2	e10110	7/16" Nut
8	2	e10111	7/16" Lockwasher
9	2	e10109	7/16" Bolt

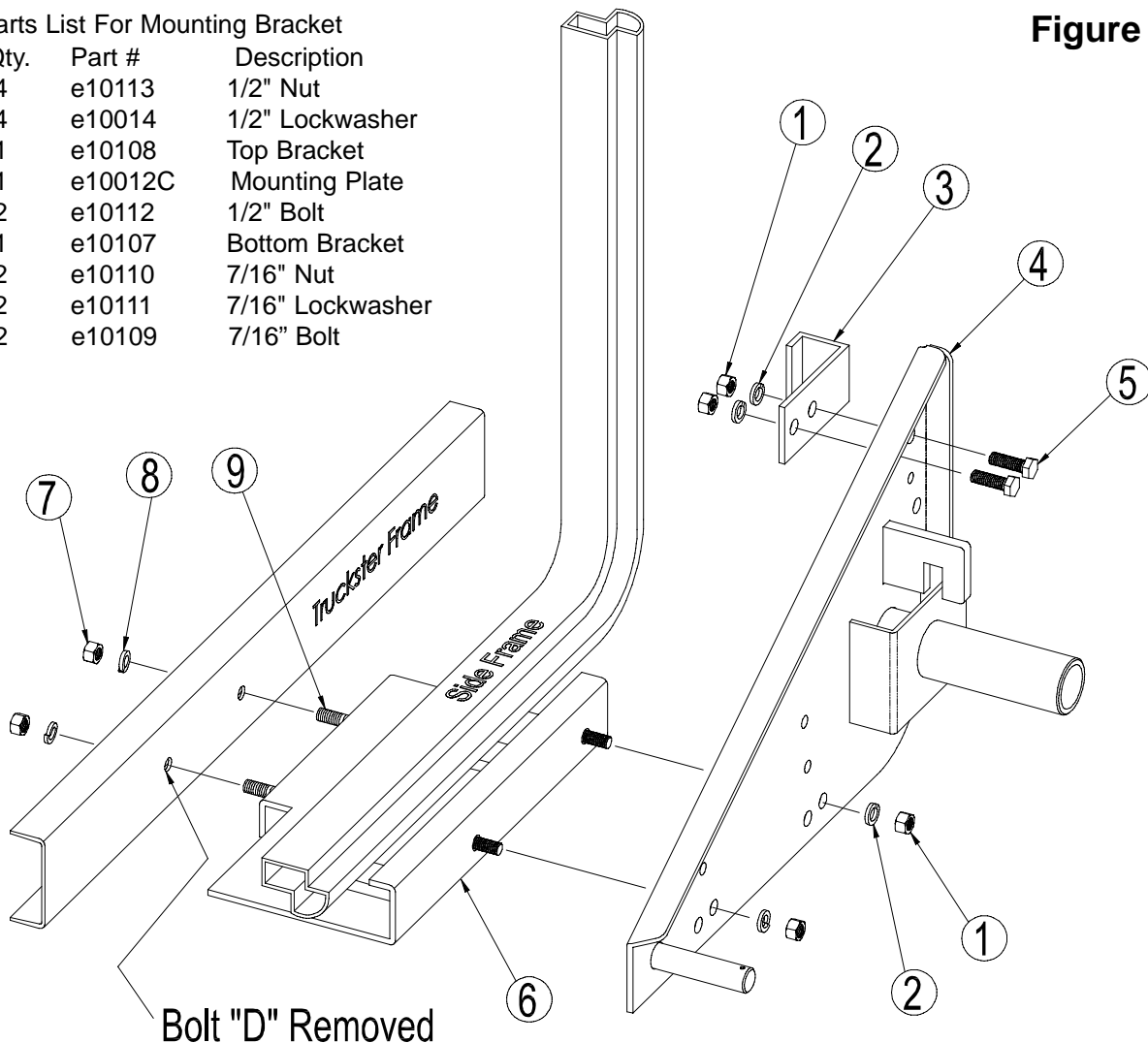

Figure #2

Kutting Edge Mounting Instructions

Older Model CUSHMAN® TRUCKSTER

Loosen fuel tank on the **LEFT SIDE** of the truckster and pull the tank away allowing the tank to slide partially out. This is important in order to **AVOID DRILLING INTO THE FUEL TANK** when installing the mounting plate.

When installing the edger on the "older" Cushman® trucksters, four (4) holes will be drilled into the frame. The holes used for installing the side mounting plate are designated by the letter [A] on the Mounting Template illustration (See sheet #2).

Locate the mounting plate (See Figure #2 Item #4) as a guide, to the vertical side brace of the Cushman® truckster with the right edge of the plate being even with the outer edge of the side brace and the bottom edge of the mounting plate even with the bottom edge of the lower frame of the Cushman®. Ignore the two tabs welded to the backside of the mounting plate. These are not loctors for this installation. Clamp the plate securely to the side brace and lower frame.

Using the four (4) ½" x 1-¼" carriage bolts included, secure the side mounting plate to the side frame of the Cushman® truckster with the ½" lock washers and ½" nuts also included. Insert the carriage bolts in from the backside of the side frame, so that the lock washers and nuts are visible on the side mounting plate. When this is completed reinstall the fuel tank.

Installing The Edger Head Assembly

(See page 6 for details)

Now insert the round end of the Main Coultter Frame into the open end of the Main Control Arm. Secure the Main Coultter Frame Assembly to the Main Control Arm using one a 1/2" bolt through the hole at the end of Main Coultter and Main Control Arm. Fasten with lockwasher and hex nut provided.

Mount the Coultter Carrier Frame to the Main Coultter Frame Assembly by inserting the pivot post of the Coultter Carrier Frame into the bushing collar on the Main Coultter Frame Assembly. (*Note: In order to make this part of the installation easier, it is recommended to lightly coat the pivot post with grease.*)

Attach the stationary end of the hydraulic cylinder to the mounting pin on the front of the side mounting plate. Secure the hydraulic cylinder to the mounting pin by inserting the hair pin.

Attach the main control arm to the side mounting plate by sliding the flanged end of the edger arm over the stationary shaft welded to the side mounting plate. Locate the notch on the flange end of the main control arm and line up with welded retainer bracket. Rotate the main control arm counterclockwise while pushing in at the same time. Once the unit is behind the welded retaining bracket, lower the main control arm towards the front of the Truckster. Attach the dynamic end of the hydraulic cylinder to the tab on the flanged end of the main

control arm. Secure with one (1) cylinder pin and two (2) quick pins.

Connect the hoses to the proper connections at the remote hydraulic box behind the driver's seat of the Cushman Truckster. When hoses are properly connected, start the Cushman Truckster and cycle the cylinder several times to get the air out of the lines and the cylinder. It may be necessary to remove the side plate of the Truckster using the access holes provided in the side plate to get to the hydraulic reservoir. You will need to add approximately one (1) pint of 10W40 motor oil to the hydraulic system.

Parts List For "Kutting Edge" Edger

Item #	Qty.	Part #	Description
1	1	e10018N	Main Control Arm
2	1	e10061	1/2-13 x 3" Hx Hd Bolt
3	2	e10043	3/8-16 Hx Nut
4	1	e10042	3/8-16 x 5" Eyebolt
5	1	e10037	Spring
6	3	e10014D	1/2-13 Hx Nut
7	2	e10038	1/2" Carrier Bearing
8	2	e10060	Spacer
9	1	e10033N	Coulter Guard
10	1	e10026	Coulter Hub
10-A	1	e10026F	Coulter Hub With Bearing
11	1	e10013	Disc
12	4	e10026B	3/8-16 x 1-1/4" Bolt
13	2	e10014B	1/2" Flat Washer
14	1	e10014	1/2-13 x 5-1/2" Mounting Bolt
15	1	e10026A	Coulter Bearing
16	4	e10026D	3/8-16 Hx Nut
17	1	e10014E	1/2"x 1" Spacer
18	2	e10014C	1/2" Lock Washer
19	1	e10022A	Coulter Carrier Frame
20	2	e10039	Bushing
21	4	e10034B	1/4-20 x 1/2" Hx Hd Bolt
22	4	e95001	1/4-20 Hx Nut
23	1	e10025A	Main Coultter Frame
24	1	e10040	Lynch Pin
25	1	e10062	Caution Decal
26	1	e10016	#10 Hairpin
27	1	e10019	Hydraulic Cylinder
28	2	e10030	53" Hydraulic Hose
29	1	e10032	Female Quick Connect Adapter
30	1	e10031	Male Quick Connect Adapter
31	2	e10021	1" Haipin Clip For Pin
32	1	e10020	1" Cylinder Mounting Pin

See Figure #3

Illustrated Parts List

For Cutting Edge on Cushman Truckster

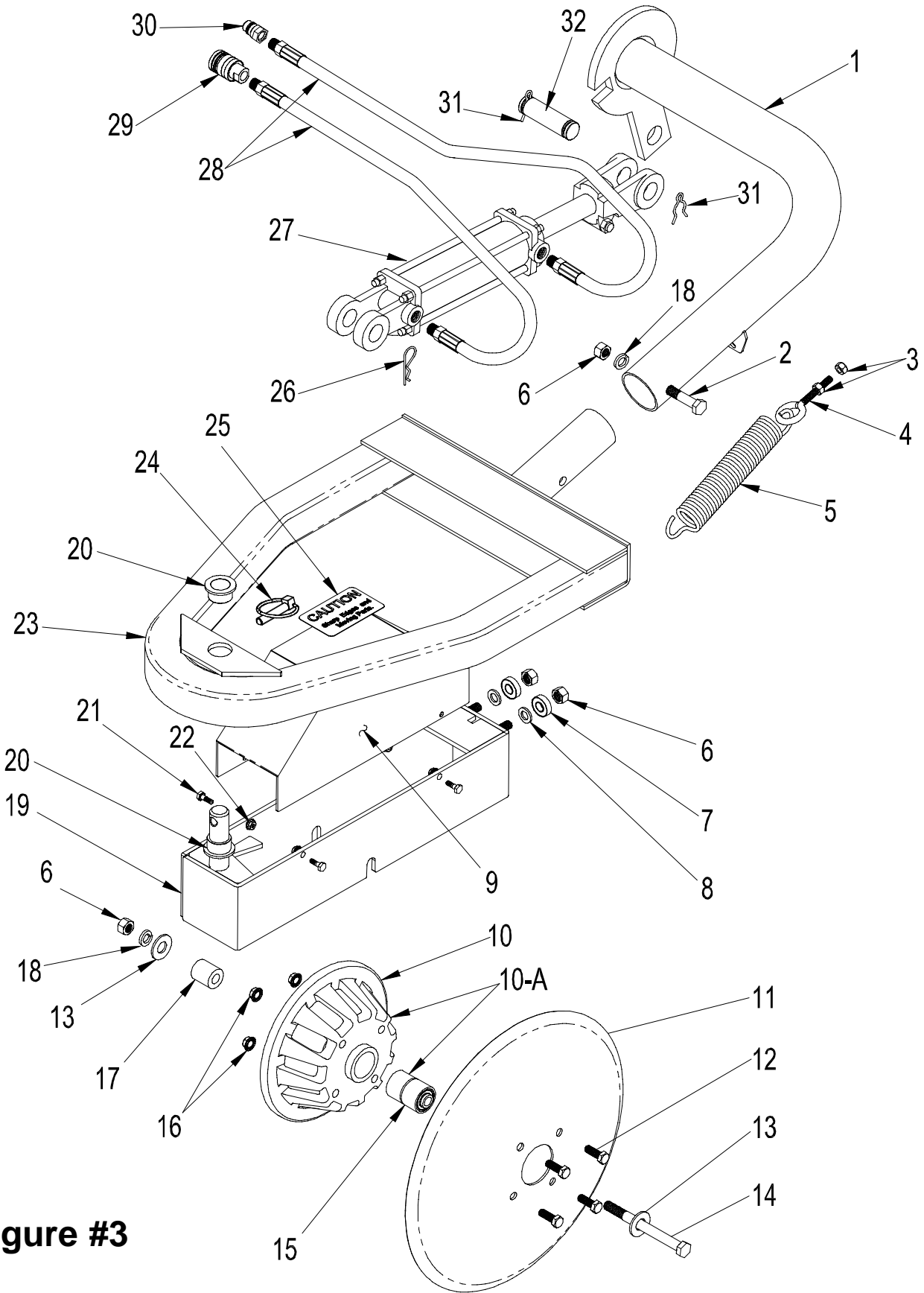
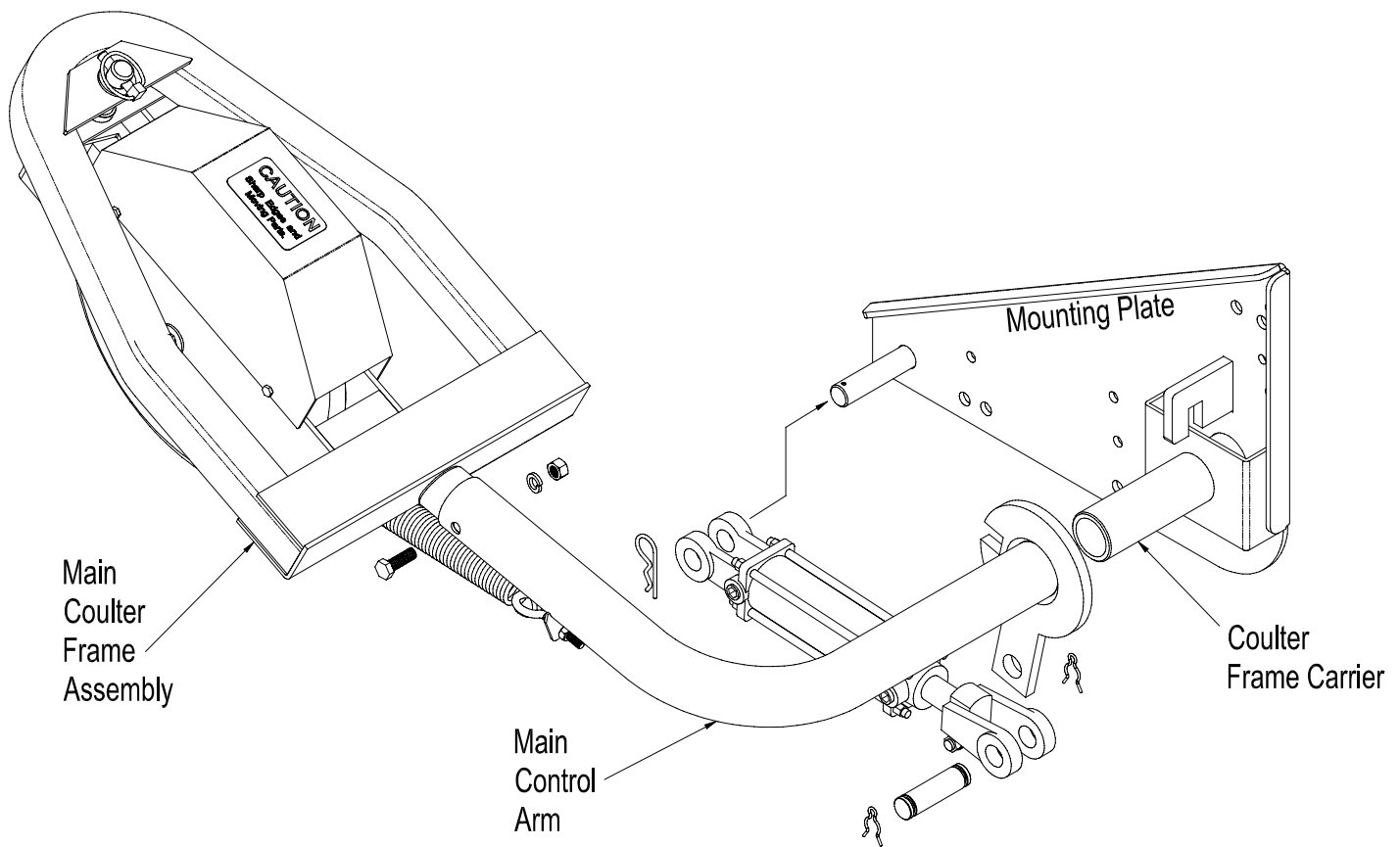

Figure #3



Hanging the BEI Edger onto the Mounting Plate per instructions on page 4.
 Hydraulic hoses not shown

BISHOP ENTERPRISES, INC.

9033 Shelbyville Hwy. Bell Buckle, TN 37020
 Tel: 615.793.6052 Fax: 615.793.9525

Look For Other Great BEI Products On The Web at
www.turf-aire.com

