

# TOW-Z

## Commercial Tow Mower Models K018M60S

Owner's Manual  
035081

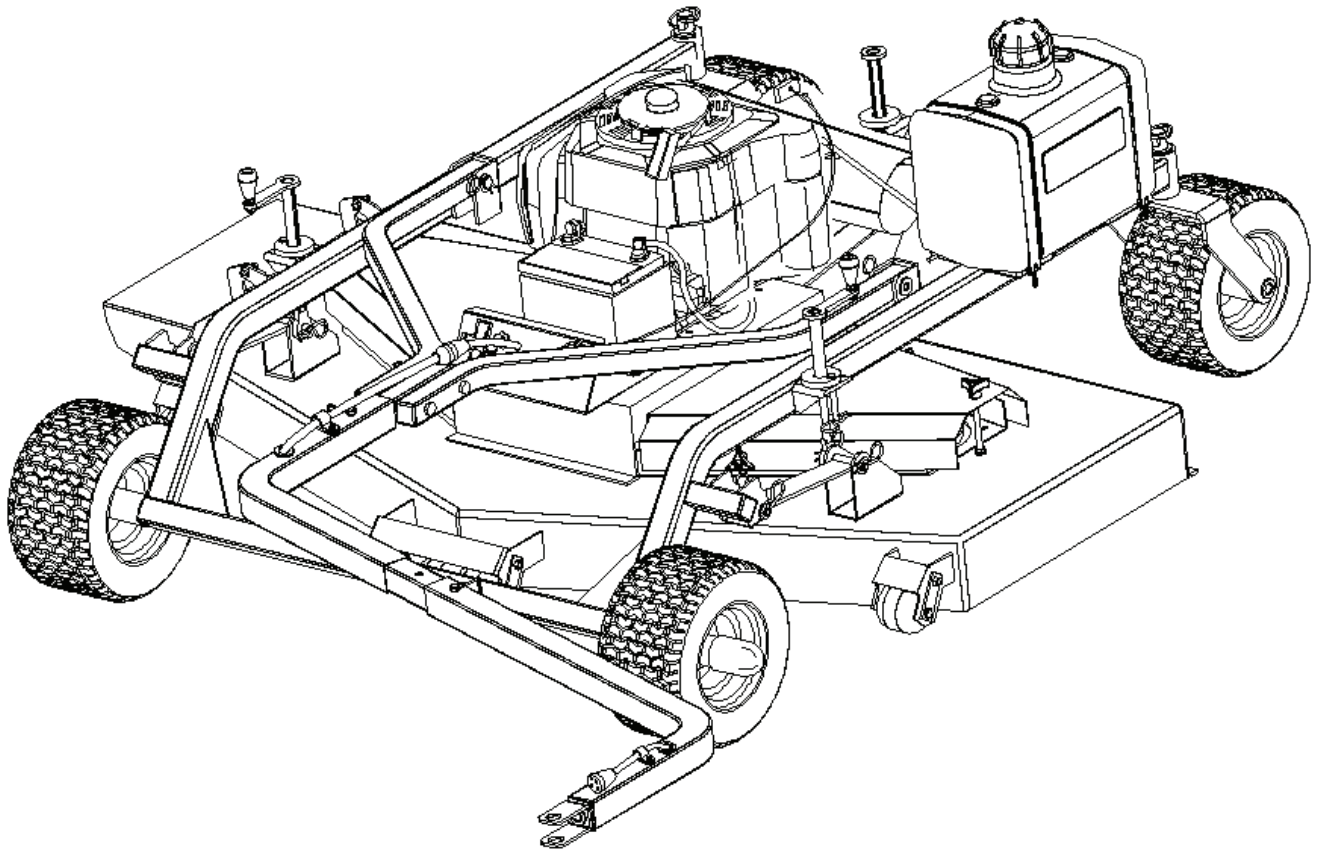

### **BISHOP ENTERPRISES, INC.**

9033 Shelbyville Highway Bell Buckle, TN 37020

Phone: 615-793-6052 Fax: 615-793-9525

email: [bishop.enterprises@comcast.net](mailto:bishop.enterprises@comcast.net)

Visit [www.turf-aire.com](http://www.turf-aire.com) for information on our full line of BEI products.



## Warning! Caution!

- **DO NOT** allow children or persons without proper instructions operate the unit.
- **Be AWARE** of your surroundings. Watch out for holes or deep depressions in the landscape. Inspect area for objects that may present a safety hazard or cause damage to the unit, (large rocks, cans, bottles, etc.). **AVOID** rough terrain.
- **DO NOT** leave towing vehicle unattended while engine is running.
- **DO NOT** permit persons to ride on the Tow-Z Mower frame at any time.
- Keep **ALL** shields, guards and safety devices in place and in proper working condition.
- **ALWAYS STOP** engine and remove spark plug wires and remove ignition key before adjusting, servicing, or performing maintenance.
- Tow-Z unit must be pulled with discharge on operators right side to avoid being injured by debris.

### Service & Parts Information

All information, illustrations and specifications contained herein are based on the most current product information available at the time of publishing. Bishop Enterprises, Inc. is dedicated to the continuous improvement of our products. Therefore we reserve the right to make changes at anytime without prior notice. If a change is made to your TOW-Z mower, which is not reflected in this operators manual or any associate illustration or parts list, see your TOW-Z distributor/dealer for current information and updates.

TOW-Z products should **NEVER** be modified unless it is by the installation of factory authorized kits listed in this manual. Any such modifications must be authorized by the manufacturer. Use only original equipment (O.E.M.) replacement parts. **Remember:** all warranty repair and service must

be performed by an author-

ized dealer.  
**NOTE:** Any unauthorized alterations or modifications to the TOW-Z mower releases Bishop Enterprises, Inc. from any warranty agreement and liability resulting from use of the modified equipment.

### Safe Operation Procedures

#### TRAINING:

1. Read this manual carefully and question your dealer if something is unclear.
2. Be thoroughly familiar with the controls and proper use of the equipment.
3. Never allow children, teenagers, or persons unfamiliar with commercial mowers to operate the mower.
4. Do not mow while people, particularly children, or pets are nearby.

#### PREPARATION:

1. The use of personal protective equipment such as (but not limited to) protection for the eyes, ears, feet and head are recommended.
2. Never operate the mower without proper guards, covers, safety switches and devices in place and properly functioning. Inspect these items daily for their condition and proper operation. If the condition or operation of these devices is questionable they must be replaced or repaired before using the mower.
3. Thoroughly inspect the area to be mowed and remove all stones, sticks, wire and other debris that may be thrown by the mower. Also note or mark other obstacles such as holes, stumps etc.
4. Do not operate the mower when barefoot or wearing open shoes. Always wear substantial footwear and long pants.
5. Fill gas tank before starting the mower. **DO NOT SMOKE** near gasoline containers. **DO NOT** fill gas tank indoors or when the engine is **HOT** or running. Clean off any spilled gasoline before starting the mower.

#### OPERATION:

1. Mow only in daylight or good artificial light.
2. Do not operate the mower in wet grass if possible.



3. **NEVER OPERATE THE TOWING MOWER WITHOUT THE WINDROW CHUTE IN THE DOWN**

#### POSITION ON THE TOWING UNIT!

4. Mow up and down slopes. Use extreme caution when mowing or turning on slopes. Always turn to the downhill direction. **DO NOT** mow excessively steep slopes (**mower may tip over and cause serious injury or death**).
5. Use caution when backing up.
6. Stop the blade when crossing surfaces other than grass; or when traveling to or from the area to be mowed.
7. Never operate the mower with defective, broken or excessively worn parts. Keep all shields, guards and safety devices in place and in proper working order.
8. Do not change the engine governor settings or over speed the engine. Operating the engine at excessive speeds will increase the hazard of injury and can severely damage the machine.
9. Keep hands, feet and clothing away from rotating parts at all times.
10. **NEVER** make adjustments to the mower while engine and/or blades are running.
11. After striking a foreign object, stop the mower and remove key. Inspect the mower for any damage and repair it immediately before continuing to mow.
12. Never operate the equipment in an enclosed or contained area without proper ventilation of the engine exhaust.
13. Do not allow any passengers to ride the mower. Keep others away from the mower when in operation.

## Transportation:

1. Use a heavy duty trailer to haul the mower. Turn off fuel valve and strap mower to the trailer. Be sure to tie down the mower to the trailer.
2. Keep all nuts, bolts and screws tight to keep mower in safe operating condition.
3. Never store the mower with gasoline in the tank inside a building where fumes could reach an open flame or be ignited by a spark.
4. Engine maintenance should comply with the engine manufacturer's specification found in the engine manual.
5. To reduce the risk of fire keep the mower free of grass, leaves and excessive grease or oil.
6. Have your mower inspected and serviced each year by an authorized dealer.
7. Use only authentic replacement parts to insure the safety and quality of your TOW-Z mower is maintained.
8. Safety decals should be replaced if they are missing or illegible. Decals can be purchased through your authorized dealer.

## Maintenance:

1. Engine oil level: Check daily with engine cold and on a flat surface. Remove the dipstick and wipe clean. Reinsert the dipstick all the way, but do not

screw down. Remove the dipstick and check oil level. If oil level is low add oil. Use engine manufacturer's specs for oil type.

2. Mower blades: Stop engine and remove ignition key. Inspect blades and sharpen or replace as needed. Check daily or more often if possible. The machine requires more power with dull blades and produces a poor uneven cut. If blades are bent, replace them. Blades should not have any notches from hitting objects. The air foil on top of the blade should be sufficient to raise the grass for cutting. If blades are in good condition, sharpen at an angle of 22 to 28 degrees about 2-1/2 inches in from the blade tip. **NOTE:** After sharpening, check blades for proper balance. Correct unbalanced blades to prevent excessive vibration.
3. Safety interlock system: Check daily and never operate the TOW-Z mower if this system is not functioning properly. If the mower starts with any of these controls on or in an operating position, turn the mower off and repair the system immediately.
4. Engine oil: Change oil to manufacturer's specifications. Stop engine and remove ignition key. Drain oil with engine still "warm". Remove 3/8 inch

hex cap from end of drain tube and empty into appropriate container. Replace hex cap. Remove oil filter. Replace with new oil filter by applying a film of oil to the gasket and then install. Refill engine according to the specified amount in the engine manual. Start engine and let idle slowly to allow oil to recoat the interior of the engine, inspect for leaks.

5. Tire pressure: Tires are 13 inch, 4 ply. Recommend maintain 28 psi. These types of tires are not designed for highway use.
6. Battery: On electric start units is a maintenance free unit.
7. Belts: Check at least every 25 hours of mowing time. Stop engine, remove ignition key. Check the condition of the drive belt. Replace excessively worn or cracked belts immediately. **See Fig 5**
8. Lubrication: Lubricate grease zerks located on all four wheels, both rear swivel yokes and at both idler pulleys. **DO NOT** get any grease on the idler pulleys or the belt. Apply grease at least every 25 hours of mowing time.



9. **Clean air intake screen regularly during use to prevent engine damage.**

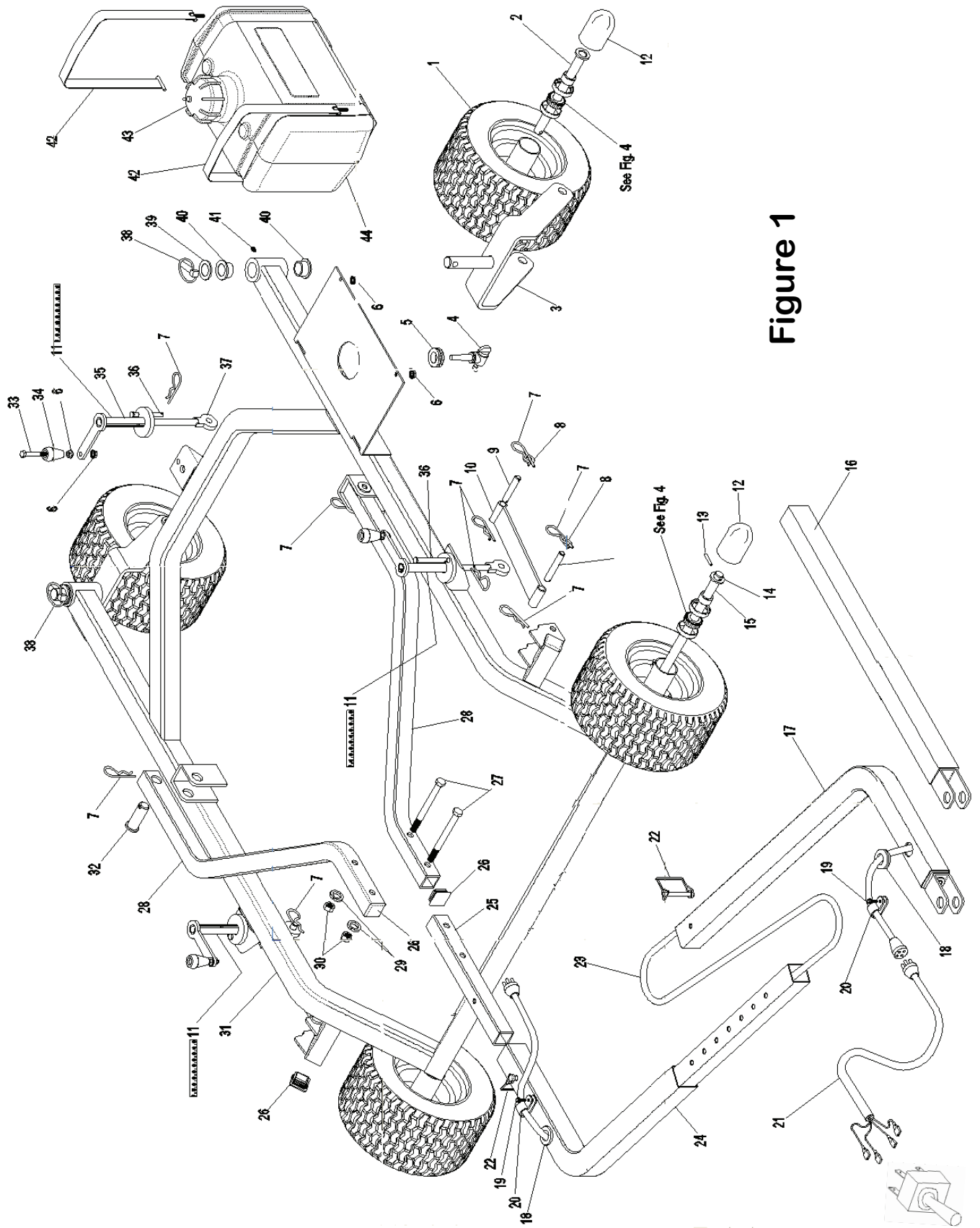
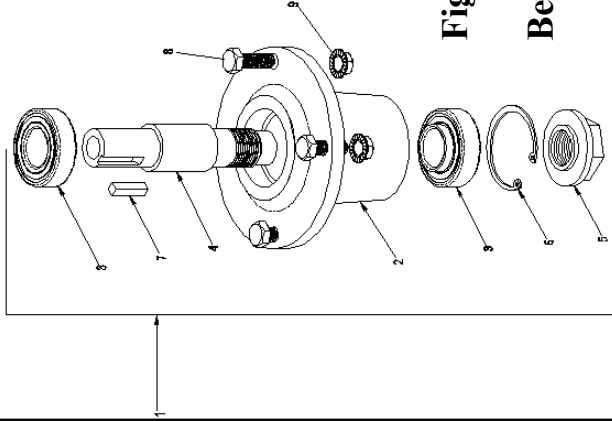

Figure 1

Item #	Part #	Description	Qty
1	034051	Bearing Housing Assy.	1
2	034051-A	Machined Housing	1
3	034051-B	Bearing	2
4	034051-D	Bearing Protector	1
5	036015	Shaft	1
6	034051-E	Retaining Ring	1
7	034087	1/4" Sq. x 1.0" Key	1
8	034096	Bolt, 3/8-16 x 1"	4
9	034052	Nut, 3/16-16 Serrated	4



**Figure 3**  
**Bearing Housing Assembly**

Item	Part Name	Part #	Qty
1	Wheel Assy	033020	1
2	Tire	033020-A	1
3	Grease Zerk	033020-B	1
4	Hub	033020-C	1
5	Valve Stem	033020-D	1
6	Race	033020-E	2
7	Bearing	033020-F	2
8	Seal	033020-G	2
9	Spacer	033020-H	2
10	Wheel Cap	033020-I	2

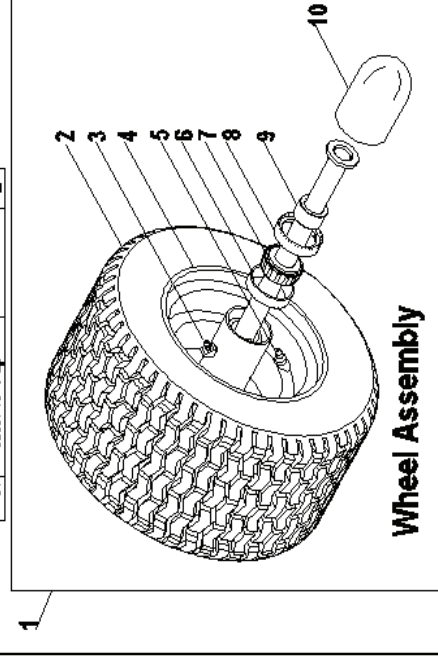

**Wheel Assembly**

**Used on These Models**

Item #	Part #	Description	Qty.	K018M60S	K025E60S	K025E72S
1	033020	Wheel	4	X	X	X
2	033006	Rear Axle	2	X	X	X
3	033004	Yoke	2	X	X	X
4	034069	Fuel Valve	1	X	X	X
5	034070	Fuel Valve Grommet	1	X	X	X
6	034058	1/4-20 Flanged Nut	8	X	X	X
7	033014	#10 Hair Pin	15	X	X	X
8	034016	1/2" Washer	8	X	X	X
9	034014	Drag-Link pin	5	X	X	X
10	034038	Drag-Link	2	X	X	X
11	034009	Adjustment Decal	3	X	X	X
12	034044	Wheel Cap	2	X	X	X
13	033021	3/16" x 1-3/8" Roll Pin	4	X	X	X
14	030099	3/4" Flat washer	4	X	X	X
15	034035	Front Axle	1	X	X	X
16	034040	Loading Hitch	1	X	X	X
17	034043	Tow Bar Hitch	1	X	X	X
18	034106	Bushing	2	X	X	X
19	034075	#10 Screw	2	X	X	X
20	034107	Wire Clamp	2	X	X	X
21	034103	Harness (C)	1	X	X	X
22	033024	Tab Lock Pin	2	X	X	X
23	034104	Harness (D)	1	X	X	X
24	034030	Tow Bar,	1	X	X	X
25	034031	Tow-Bar Link	1	X	X	X
26	031106	Cap Plug (1-1/2" Sq.)	4	X	X	X
27	031103	Bolt, 1/2-13 x 5-1/2"	2	X	X	X
28	034029	Tow-Mower Arm	2	X	X	X
29	033026	Washer, 1/2" Lock	2	X	X	X
30	030049	Nut, 1/2"-13	2	X	X	X
31	034001	Tow-Z Frame	1	X	X	X
32	034027	Hitch Pin	2	X	X	X
33	034057	Bolt, 1/4-20 x 2-1/2"	3	X	X	X
34	034056	Knob	3	X	X	X
35	034017	Adjustment Arm	3	X	X	X
36	034079	Clevis Pin, 3/8" x 3"	3	X	X	X
37	034015	Deck Adjustment Bolt	3	X	X	X
38	033022	Lynch Pin, 7/16" x 2	2	X	X	X
39	033048	Spacer	2	X	X	X
40	033023	Bushing	4	X	X	X
41	031011	Grease Zerk	2	X	X	X
42	034037	Tank Strap	2	X	X	X
43	034068	Fuel Cap	1	X	X	X
44	034013	5 Gallon Fuel Tank	1	X	X	X
107	034076	Clutch Toggle Switch	1	X	X	X



Used on These Models

Item #	Part #	Qty.	Description	K018M60S	K025E60S	K025E72
84	034025	1	Large Anti Scalp Pin	X	X	X
85	034008	1	Danger Decal	X	X	X
86	034028	1	Control Panel	X	X	X
87	034060	1	Hour Meter	X	X	X
88	034045	1	Manual Choke	X	X	X
89	034113	2	Ignition Key	X	X	X
90	034059	1	Ignition Switch ES	X	X	X
90	034091	1	Ignition Switch MS	X		
91	034061	1	Throttle Control	X	X	X
92	034099	1	Battery Box	X	X	X
93	034113	1	Positive Battery Cable	X	X	X
94	034053	2	Nut, 5/16-18 Staked	X	X	X
95	034054	2	Bolt, 5/16-18 x 3/4"	X	X	X
96	034097	1	12 Volt Battery	X	X	X
97	034105	1	Ground Battery Cable	X	X	X
98	034012	1	Discharge Chute	X	X	X
99	034019	1	RH belt & Pulley Cover	X	X	X
99	036008	1	RH belt & Pulley Cover			X
100	033047	1	Hairpin Clip	X	X	X
101	034010-Y	1	Nut, 5/16-18 Hex	X	X	X
102	034095	1	Spring	X	X	X
103	034021	1	Backside Idler Arm	X	X	X
104	034064	4	Bolt, M8 1.25 x 30mm	X		
105	034110	4	Bolt, 5/16-18 x 2-1/4"	X	X	X
106	034115	1	3/8" Eye Bolt	X	X	X

Item #	Part #	Qty.	Description	K018M60S	K025E60S	K025E72S
45	034063	1	CV493T 18 HP Kohler	X		
45	034083	1	CV730S 25 HP Kohler		X	X
46	034062	1	Electro-Clutch	X		
46	036011	1	Electro-Clutch		X	X
47	034013	1	7/16 Lock Washer	X	X	X
48	034080	1	Bolt, 7/16-20 x 2-1/2"	X	X	X
49	034087	3	1/4" Sq. x 1.0" Key	X	X	X
50	034011	2	Spacer	X	X	X
51	034073	1	3/8" NPT Hex Cap	X	X	X
52	034071	1	Drain Hose	X	X	X
53	034102	2	Fuel Line Clamp	X	X	X
54	034078	1	Fuel Line Hose	X	X	X
55	034100	1	A- Style Harness	X	X	X
55	034101	1	B- Style Harness	X		
56	034086	3	Bolt, 5/8-18 x 1-3/4"	X	X	X
57	034094	3	5/8" Flat Washer	X	X	X
58	034065	3	5" Steel Pulley	X	X	X
59	034096	16	Bolt, 3/8-16 x 1"	X	X	X
60	034051	3	Bearing Housing Assy.	X	X	X
61	034010	1	5ft Deck	X	X	X
61	036001	1	6ft Deck			X
62	034022	2	3/8-16 x 4-5/8" All Thd.	X	X	X
63	034005	2	Warning Decal	X	X	X
64	034041	2	Warning Decal	X	X	X
65	034018	1	LH Belt Cover	X	X	X
65	036009	1	LH Belt Cover			X
66	034055	6	Belt Cover Knob	X	X	X
67	030045	2	Danger Decal	X	X	X
68	034052	9	Nut, 3/16-16 Serrated	X	X	X
69	034084	3	Mowing Blade 60"	X	X	X
69	035014	3	Mowing Blade 72"			X
70	034108	3	Washer, 5/8" Lock	X	X	X
71	034093	3	Bolt, 3/8-18 x 3-1/2"	X	X	X
72	034026	2	Small Anti Scalp pin	X	X	X
73	034050	3	Bolt, 3/8-16 x 3/4"	X	X	X
74	034049	5	Anti Scalp Roller	X	X	X
75	034004	2	Kutting Edge Decal	X	X	X
76	034088	1	Belt 60"	X	X	X
76	036010	1	Belt 72"			X
77	034007	1	Spacer	X	X	X
78	034066	2	6" Idler Pulley	X	X	X
79	034117	1	Bolt, 5/8-18 x 3.0"	X	X	X
80	034039	1	Tow-Z Decal	X	X	X
81	034085	4	Bolt, 5/16-18 x 1"	X	X	X
82	034112	1	Control Module	X		
83	034109	4	Spacer	X	X	X

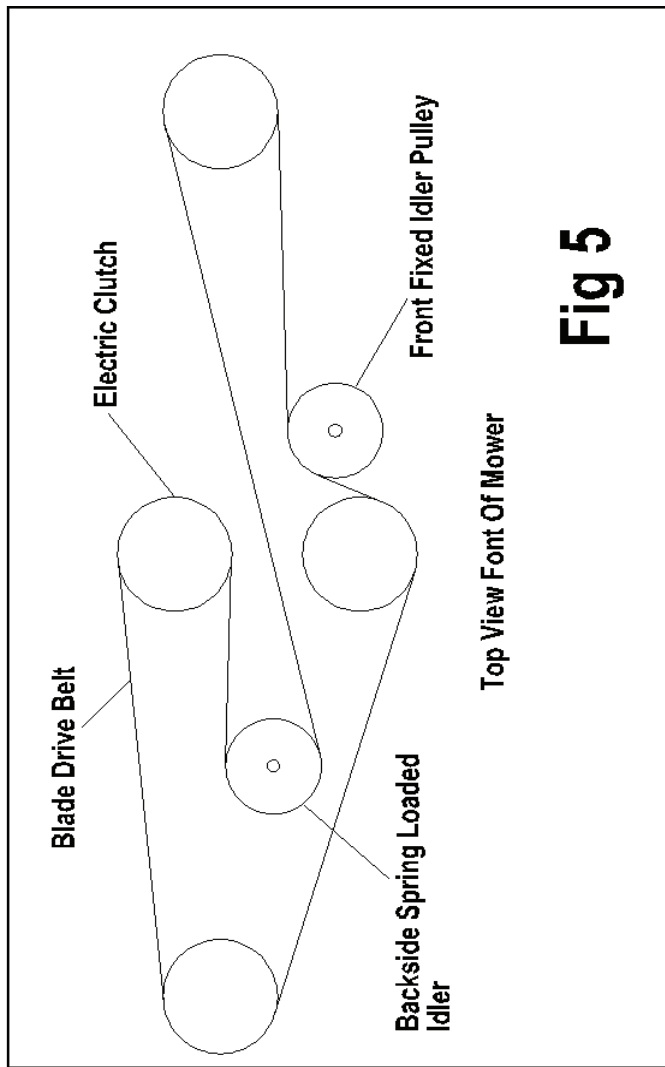

Top View Font Of Mower

Fig 5

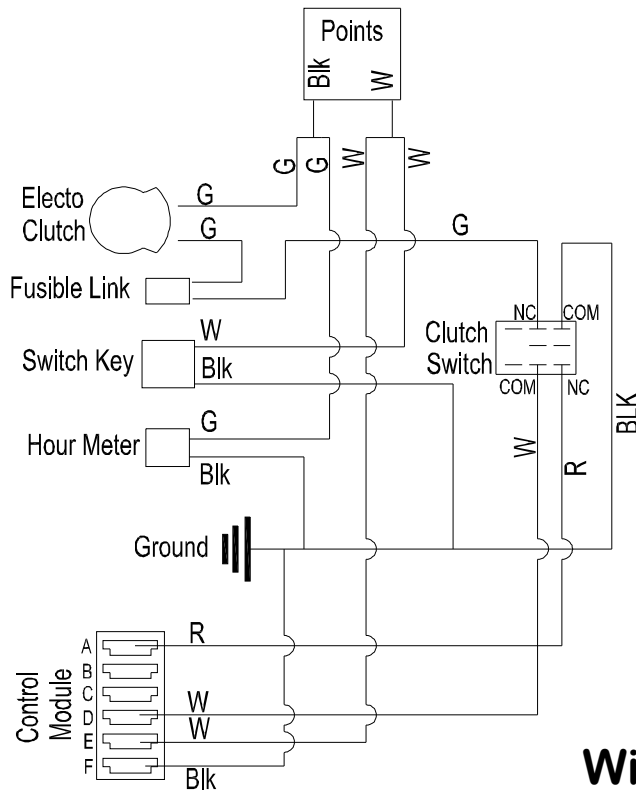

"B"-Style Wiring Harness 034101

## Wiring Diagram For Manual Start Units

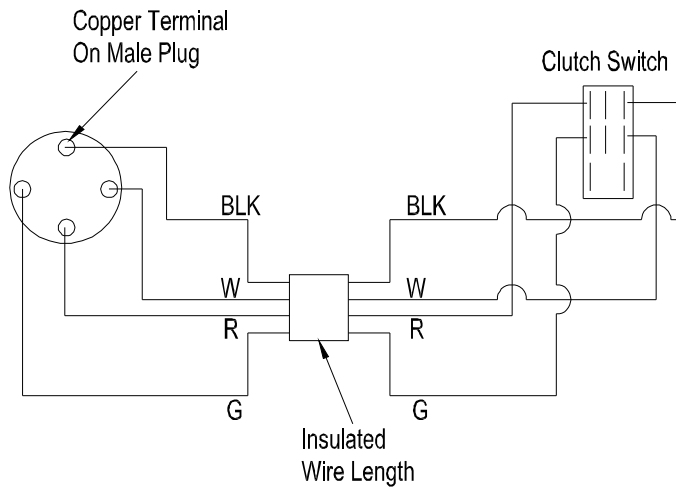

"C" Style Wiring Harness 036012

## Wiring Diagram: Clutch Switch To Plug



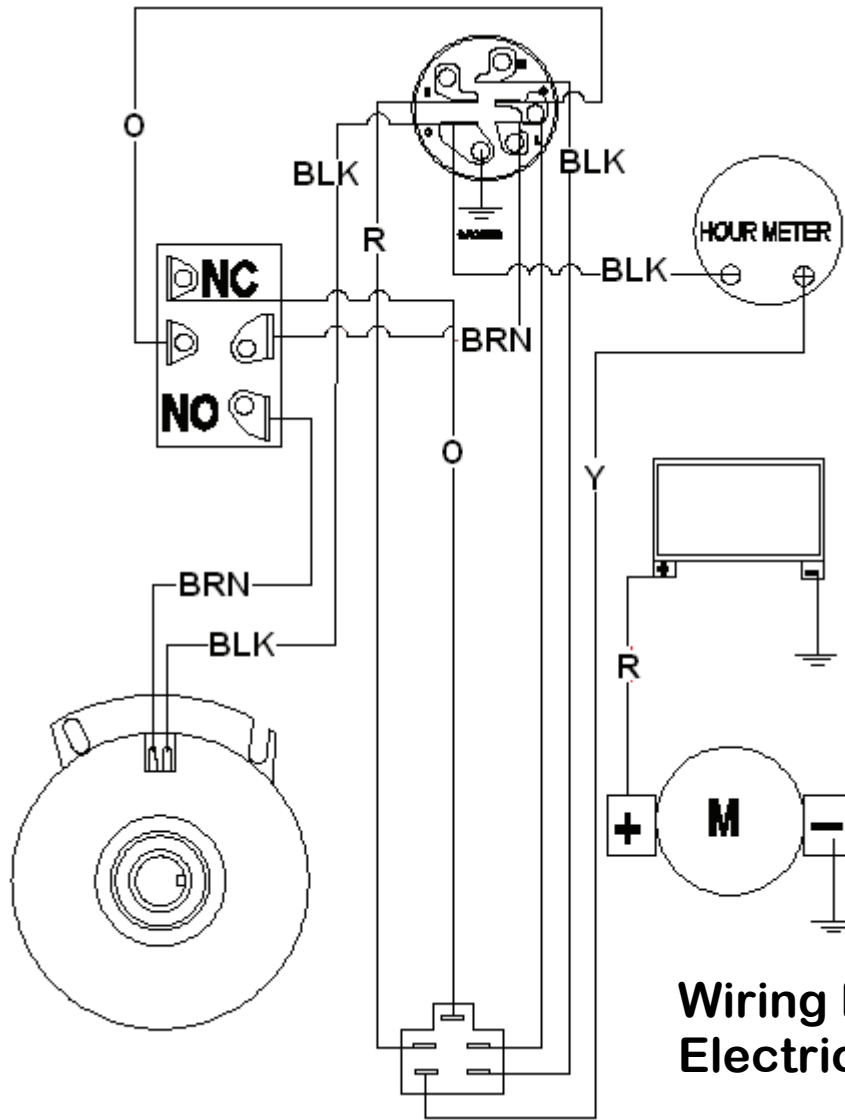

**Wiring Diagram For  
Electrical Start Units**

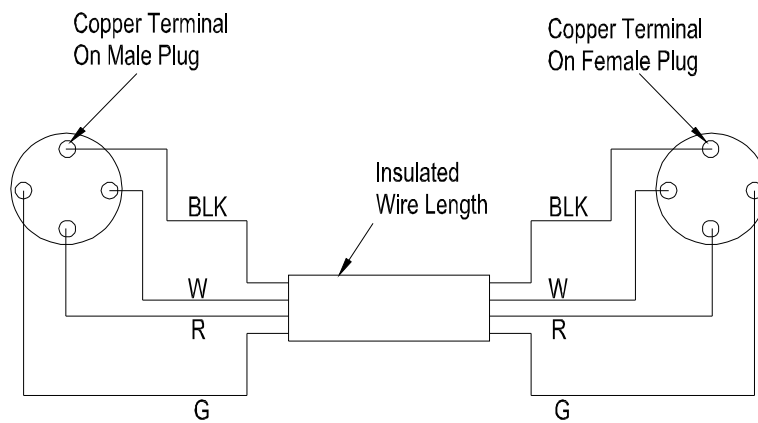

"D" Style Wiring Harness 034104

**Wiring Diagram:  
Extension Harness Through Tow Bar**

## Limited Warranty

Bishop Enterprises, Inc. (hereinafter referred to as "Bishop") warrants for one (1) year all new TOW-Z units. This warranty extends to the original retail purchaser only and commences on the date of original retail purchase. Accordingly, this warranty is not transferable to any subsequent purchasers.

Any part of the TOW-Z unit or accessory manufactured by Bishop and found in the reasonable judgment of Bishop to be defective in material or workmanship will be repaired or replaced by an authorized TOW-Z distributor/dealer without charge for parts and labor. The TOW-Z unit, including any defective part, must be returned to an authorized TOW-Z distributor/dealer within the warranty period of one-year. The owner/operator will be responsible for the expense of returning the TOW-Z unit to an authorized distributor/dealer for warranty service, as well as the expense for having it returned to them after said repair or replacement.

Bishop's responsibility is limited to making the required repairs or replacements. No claim of breach of warranty shall be cause for cancellation or rescission of the contract of sale of any TOW-Z unit. Proof of purchase will be required by the authorized TOW-Z distributor/dealer to substantiate any warranty claim and all warranty work must be performed by an authorized TOW-Z distributor/dealer.

Bishop makes no warranty with respect to engines, tires, or other parts not of their manufacture. (Such parts are usually warranted separately by their respective manufacturers.) This warranty does not include service items subject to normal wear (i.e., tires). This warranty does not cover any TOW-Z unit that has been subject to misuse, neglect, negligence, or accident, or that has been operated or maintained in any way contrary to the operating or maintenance instructions as specified in the TOW-Z Operator's Manual. The warranty does not apply to any TOW-Z unit that has been altered or modified so as to adversely affect the unit's operation, performance, or durability or that has been altered or modified so as to change its intended use. In addition, the warranty does not extend to repairs made necessary by normal wear, or by the use of parts or accessories which, in the reasonable judgment of Bishop, are either incompatible with the TOW-Z unit or adversely affect its ability to function properly.

Bishop reserves the right to change or improve the design of any TOW-Z unit, without prior notice, and without assuming any obligation to modify any unit previously manufactured.

All implied warranties are limited in duration to the applicable one-year period. All implied warranties, including merchantability, fitness for a particular purpose or otherwise, are disclaimed in their entirety after the expiration of the one-year warranty period. Bishop's obligation under this warranty is strictly and exclusively limited to the repair or replacement of defective parts, and Bishop does not assume or authorize anyone to assume for them any other obligation.